



Moooi Hubble Bubble LED Suspension

LA10270

SOURCE: <https://www.davidvillagelighting.co.uk/product/Moooi-Hubble-Bubble-LED-Suspension/20786>



PRODUCT DESCRIPTION

Designer: Marcel Wanders

Hubble Bubble by Moooi

A light that is meant to take you back to your childhood, playing with bubbles and running around barefoot. Marcel Wanders has done it again; he designed this fantastic suspension light for Moooi. The Hubble Bubble evokes and brings inside your home an everlasting memory.

The suspension is available in two models, Hubble Bubble 7 and Hubble Bubble 11, which refers to each size's number of 'bubbles'. The glass bulbs are available in either an oil / iridescent colour or frosted. You may choose to install the suspension either horizontally, vertically or install it in an angle; a light that gives you the freedom to hang it whichever way you wish.

The Hubble Bubble lights also benefit from the **Electrosandwich®** technology, which was developed by Marcel Wanders and is exclusive for Moooi lights. The technology involves using conductive material, that will power the light throughout, without the need for wires and cables. This technique permits for endless design possibilities, and without it the Hubble Bubble would not be possible.

PRODUCT SPECIFICATION

Light Source: **Hubble Bubble 7** - 10W, 2700K, 306 Lumens
Hubble Bubble 11 - 17W, 2700K, 530 Lumens

IP Code: 20

Dimming: Dimmable via trailing edge dimming.

Dimensions: **Hubble Bubble 7**
Ring Length: 73cm
Ring Width: 13cm
Ring Height: 71cm

Hubble Bubble 11
Ring Length: 99cm
Ring Width: 13cm
Ring Height: 102cm

Ceiling Canopy: 35 x 3 x 10cm
Cable Length: 250cm

Hubble Bubble 7

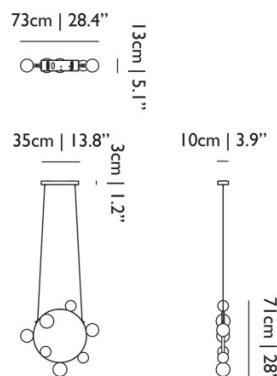

Hubble Bubble 11

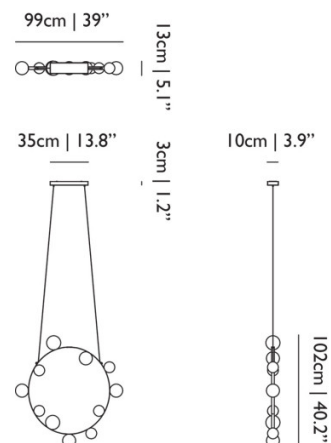



For all sales and technical enquiries, please contact:

+44 (0)114 263 4266

info@davidvillagelighting.co.uk

www.davidvillagelighting.co.uk