

NEMO

LA10095/P

Nemo Lighting Tubes 3 LED Pendant

SOURCE: <https://www.davidvillagelighting.co.uk/product/Nemo-Lighting-Tubes-3-LED-Pendant/20356>



PRODUCT DESCRIPTION

Designer: Charles Kalpakian

Tubes 3 Pendant by Nemo Lighting

Part of the [Tubes collection](#), designed by Charles Kalpakian for Nemo. Charles draws inspiration from his roots in France and Lebanon. He creates motifs that take inspiration from the decorative arts, which in turn have been inherited from Lebanese history and geography.

Tubes 3 is a suspended luminaire composed of three cylindrical elements which have a polycarbonate diffuser, allowing for a diffused light. The pendant is available in three finish options: all white or white and copper. Tubes 3 is also dimmable, using TRIAC dimming systems. The collection includes wall and ceiling lights with adjustable elements in different arrangements.

PRODUCT SPECIFICATION

- Light Source:** 12W, 2700K, 560 lumens
- IP Code:** 20
- Dimming:** Dimmable using Triac dimming.
- Dimensions:** 24 cm width
19 cm depth
50 cm height
Ø11 cm x 3 cm ceiling canopy
3m cable length

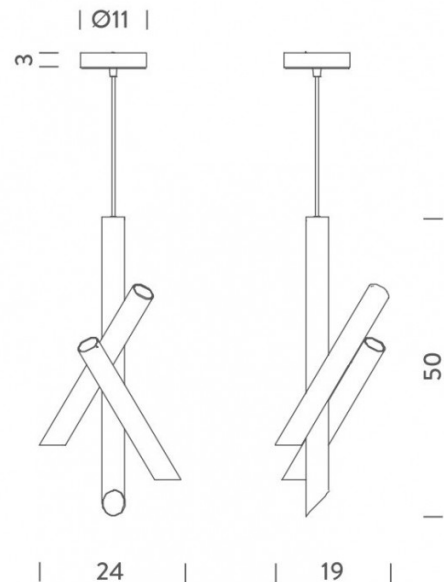

For all sales and technical enquiries, please contact:

+44 (0)114 263 4266

info@davidvillagelighting.co.uk

www.davidvillagelighting.co.uk