

**prandina**  
LIGHTING STORIES

# Prandina Landing S70 LED Pendant

LA5710

SOURCE: <https://www.davidvillagelighting.co.uk/product/Prandina-Landing-S70-LED-Pendant/19561>



## PRODUCT DESCRIPTION

**Designer:** Sergio Prandina

### Landing S70 LED Pendant Light by Prandina

Made from three parts, the Landing S70 pendant is a minimalist and intriguing light that produces an upward and downward light to fit all your needs. The middle part has an integrated LED light source which shines upwards onto the upper metal shade. This upper shade then diffuses the light, providing an ambient glow that is glare-free. The downward light is provided by a smaller hanging light underneath that uses a GU10 lightbulb, which is not included in the purchase.

The Landing S70 pendant light is available with two finishes on the upmost shade, a matt white or brass galvanized. The size of the pendant make it perfect as a stand-alone feature light to illuminate your lounge, kitchen, dining room or reception room. Being completely versatile and chic, you can also match it with other lights from the [Prandina Landing collection](#) to create a coherent design scheme.

## PRODUCT SPECIFICATION

**Light Source:** 1 x DRPAR GU10 6W max (excluded)

**IP Code:** 20

**Dimming:** Dimmable via mains phase dimming

**Dimensions:** Ø60cm shade  
54cm shade height  
Ø12cm ceiling rose  
3m cable length

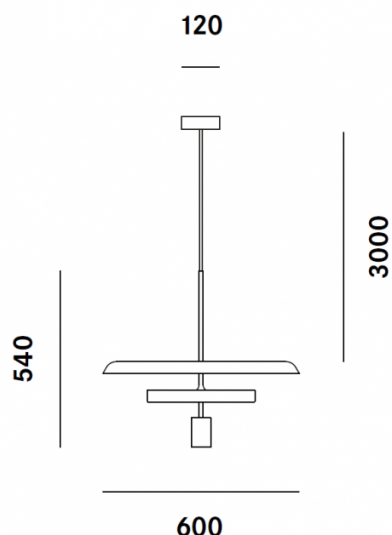



**For all sales and technical enquiries, please contact:**

+44 (0)114 263 4266

[info@davidvillagelighting.co.uk](mailto:info@davidvillagelighting.co.uk)

[www.davidvillagelighting.co.uk](http://www.davidvillagelighting.co.uk)