



Slamp Hugo LED Suspension

LA5563

SOURCE: <https://www.davidvillagelighting.co.uk/product/Slamp-Hugo-LED-Suspension/19255>

PRODUCT DESCRIPTION

Designer: Slamp Creative Department

Slamp Hugo Suspension

The Slamp Hugo Suspension is part of a larger technical-decorative lighting system by Slamp. This luminaire combines two suspension points and achieves a high light output with low consumption, harbouring a strength and capacity of 3500 Lumen. Hugo is creative and elegant, making it perfect for illuminating any home or office space. It customises the environment with a sinuous design and the softness of LED lights, diffused evenly by the Lentiflex® - a material patented by Slamp. The prismatic surface of the synthetic material makes Hugo a fascinating eye-catcher.

Winner of the Red Dot Product Design Award, the Hugo allows you the creative freedom to generate different lamp formations to suit your interior décor style or personal preference. This is a suspension light that flows from one end of a space to another, hung and arranged parallel, slanted, or perpendicular to the ground. You can use up to seven modules to create your own personalised lighting system. The Hugo Suspension is a great addition to office spaces.



PRODUCT SPECIFICATION

- Light Source:** 25W, 3000K, 3500 Lumens
- IP Code:** 20
- Dimming:** Dimmable via Push to make/1-10V dimming systems.
Please consult your electrician, additional wiring may be required on site.
- Dimensions:** Width: 100cm
Cable Length: 140cm

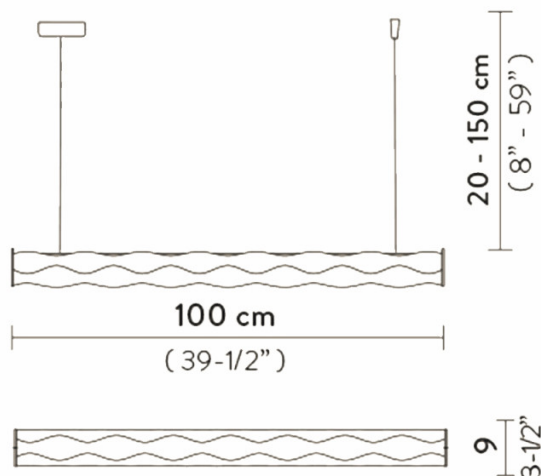



For all sales and technical enquiries, please contact:

+44 (0)114 263 4266

info@davidvillagelighting.co.uk

www.davidvillagelighting.co.uk