

HAY

HAY Fifty-Fifty LED Table Lamp

LA5549

SOURCE: <https://www.davidvillagelighting.co.uk/product/HAY-Fifty-Fifty-LED-Table-Lamp/19225>

PRODUCT DESCRIPTION

Designer: Sam Weller

HAY Fifty-Fifty LED Table Lamp

The HAY Fifty-Fifty LED Table Lamp was designed by British designer Sam Weller who uses his background knowledge of engineering and industrial design to create highly functional and well-made products, such as the Fifty-Fifty collection. Sam Weller references to his physics and engineering influence to create the lamp's counterweight system that creates equilibrium between the two parts. By basing this design on stripping back a multi-purpose task light to its fundamental elements, Weller is able to produce a simplistic yet complicated design that is easy on the eye as well as easy to use.

Fifty-Fifty balances refined, pared-back aesthetics with optimal functionality. This is seen in the joints and mechanisms that allow the single cantilever arm to easily tilt and pivot with one hand. The in-line dimmer switch also allows you to manipulate and control the light output with a touch-sensitive dimmer. This elegant, practical desk lamp is available in two finishes which are Soft Black and Ash Grey. Both finishes emphasise the lamp's unique mechanisms and design. This table lamp would be ideal for a workspace or office as it can easily direct light in and around a space, however, the design would also add an industrial feel to any interior.



PRODUCT SPECIFICATION

- Light Source:** 4W, 3000K, 360 Lumens
- IP Code:** 20
- Dimming:** Integrated dimmer on the product.
- Dimensions:**
 - Height: 60cm
 - Arm Length: 90cm
 - Width: 18.5cm
 - Max Reach: 75cm
 - Cable Length: 200cm

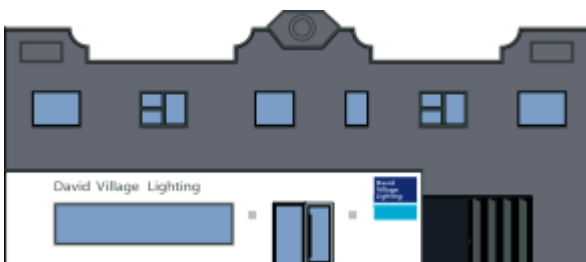
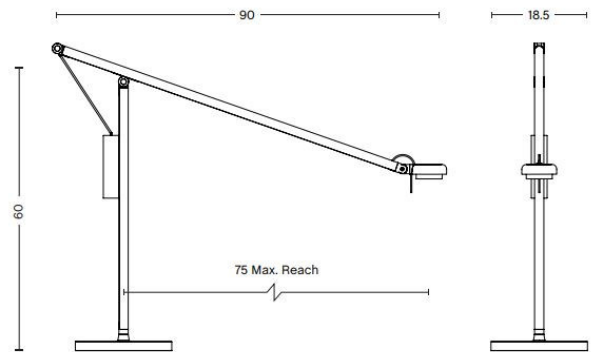

For all sales and technical enquiries, please contact:

+44 (0)114 263 4266

info@davidvillagelighting.co.uk

www.davidvillagelighting.co.uk