



# Modoluce Angelica Wall Large

LA4947

SOURCE: <https://www.davidvillagelighting.co.uk/product/Modoluce-Angelica-Wall-Large/18252>



## PRODUCT DESCRIPTION

### Modoluce Angelica Large Wall Light

Matt painted metal structure available in white, or black. Gives a beautiful soft warm light emission. A beautiful edition to any environment.

Available with either a cable and plug or as a hardwired version.

The wall light has a cantilevered arm rotating on the axis by 160 degrees.

Available in white or black with matching cotton shades. Other shade colours available on request.

Lamp excluded

## PRODUCT SPECIFICATION

**Light Source:** 1 x Max 70W E27 (excluded)

**IP Code:** 20

**Dimensions:** Shade: Ø45cm  
Shade Height: 21cm  
Depth: 200cm  
Full Height: 96cm

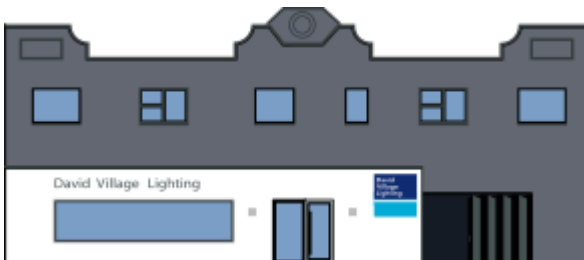
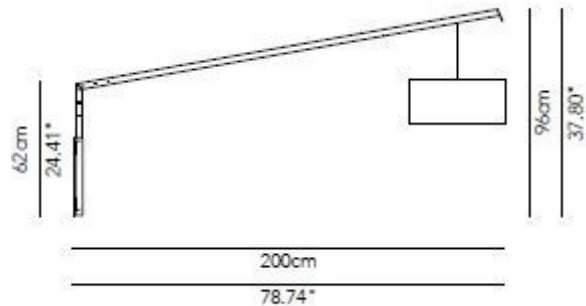

**For all sales and technical enquiries, please contact:**

+44 (0)114 263 4266

[info@davidvillagelighting.co.uk](mailto:info@davidvillagelighting.co.uk)

[www.davidvillagelighting.co.uk](http://www.davidvillagelighting.co.uk)