

# Northern Northern Birdy Swing Wall Lamp

LA4941

SOURCE: <https://www.davidvillagelighting.co.uk/product/Northern-Birdy-Swing-Wall-Lamp/18246>



## PRODUCT DESCRIPTION

**Designer:** Birger Dahl

### Northern Birdy Swing Wall Light

The Birdy Swing Wall Light is part of a modernistic lighting collection designed by Birger Dahl. Originally released in 1952, the collection was widely popular, with the table lamp being awarded the esteemed Golden Medal at the Milan Triennale. Northern re-launched the collection in 2013, taking care to preserve the original features that made it such a well-loved range. As well as the swing wall light, the collection also includes a [table lamp](#), [short wall light](#), and [floor lamp](#).

The sleek and uncluttered design gives the Birdy Swing Wall Light its modernistic style, allowing it to blend seamlessly into contemporary interiors. Ideal for both residential and commercial spaces such as offices or restaurants. The adjustable head and directional lighting create perfect task lighting beside a coffee table or as a reading light beside a bed. Alternatively, install in a row to illuminate a hallway or stairway. Available in a choice of black, brass, or steel finishes.

## PRODUCT SPECIFICATION

- Light Source:** 1 x Max 11W LED E27 (excluded)
- IP Code:** 20
- Dimming:** In-line on/off switch included on cable.
- Dimensions:**
  - Depth: 53cm
  - Height: 24cm
  - Wall Mount Height: 12.5cm
  - Cable Length: 200cm

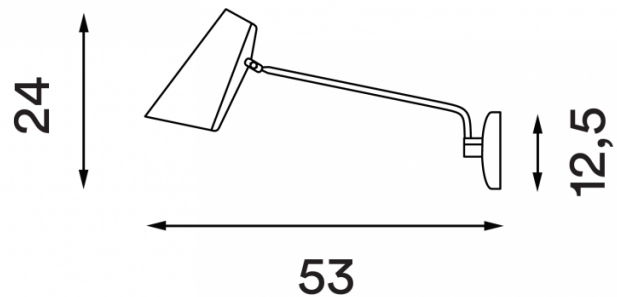



**For all sales and technical enquiries, please contact:**

+44 (0)114 263 4266

[info@davidvillagelighting.co.uk](mailto:info@davidvillagelighting.co.uk)

[www.davidvillagelighting.co.uk](http://www.davidvillagelighting.co.uk)