



Bover Dome 90 LED Pendant

LA3727/90

SOURCE: <https://www.davidvillagelighting.co.uk/product/Bover-Dome-90-LED-Pendant/17602>



PRODUCT DESCRIPTION

Designer: Benedetta Tagliabue

Bover Dome 90 LED Suspension

The Bover Dome 90 LED Pendant is a fantastic combination of design, art and light with a strong personality. The result is an eye catching light sculpture that creates a play of shadows and nuances that enrich the space for which they were created.

The Dome 90 LED Pendant light is completely handmade and entirely produced in the Bover Barcelona HQ. The LED light source rests atop the wooden shade, rather than inside of it, to illuminate throughout the open and diffused portions of the wooden frame. The wooden frame is curated from more than 165 wood fragments of multiple sizes, which are all intertwined and create beautiful lighting effects on the floor below.

PRODUCT SPECIFICATION

- Light Source:** 25W, 2700K, 2970 Lumens
- IP Code:** 20
- Dimming:** Dimmable using leading edge and trailing edge (Triac).
- Dimensions:** Shade: Ø91.5cm
Shade Height: 57cm
Maximum Drop: 400cm

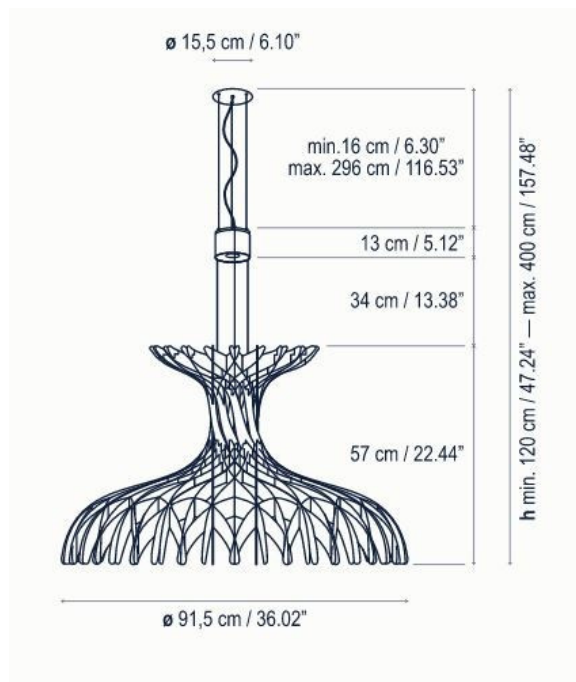

For all sales and technical enquiries, please contact:

+44 (0)114 263 4266

info@davidvillagelighting.co.uk

www.davidvillagelighting.co.uk