

marset

Marset Funiculi A Wall Light

LA4360

SOURCE: <https://www.davidvillagelighting.co.uk/product/Marset-Funiculi-A-Wall-Light/17232>

PRODUCT DESCRIPTION

Designer: Lluís Porqueras

Marset Funiculi A Wall light

The Marset Funiculi wall lamp was designed by Lluís Porqueras and embodies the designer's style and ethos of simplicity and functionality. Porqueras says 'all I wanted to do was to pare away, to pare away and to pare away until I reached the pure essence of a simple, useful object!'. This became the Funiculi wall lamp, with its industrial design and simple finish. The name Funiculi is a reference to 'funicular' meaning the action to move up and down which is the way in which the light can be adjusted. The mechanism of moving the lamp up and down is constructed of two clips that allow for easy adjustment.

Funiculi by Marset is available in six colour options and comprises of a matching table and floor lamp. This modern redesign is perfect for creating a cozy atmosphere as well as the adjustability lending itself to reading or tasks which require extra focus.



PRODUCT SPECIFICATION

- Light Source:** 1x Max 15W E14 LED (excluded)
- IP Code:** 20
- Dimming:** In line on/off switch included on cable.
- Dimensions:**
 - Depth: 29.5cm
 - Length: 49.2cm
 - Shade: Ø15.5cm
 - Cable Length: 200cm

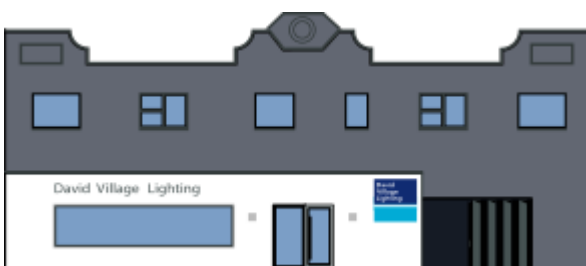
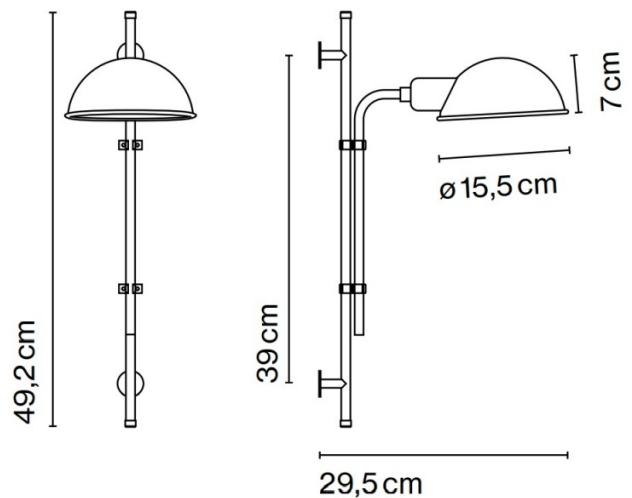

For all sales and technical enquiries, please contact:

+44 (0)114 263 4266

info@davidvillagelighting.co.uk

www.davidvillagelighting.co.uk