

marset

# Marset Funiculi S Table Lamp

LA4359

SOURCE: <https://www.davidvillagelighting.co.uk/product/Marset-Funiculi-S-Table-Lamp/17231>

## PRODUCT DESCRIPTION

**Designer:** Lluís Porqueras

### Marset Funiculi S Table Lamp

Designed by industrial designer Lluís Porqueras, this minimalist light embodies the ethos of the designer's simplistic view on design and lighting. To quote the designer *'all I wanted to do was to pare away, to pare away and to pare away until I reached the pure essence of a simple, useful object!'* This is clear within the design of the Funiculi table light as the look and functionality could not be more simple.

The work Funiculi is in reference to the work 'funicular' which means to move something up and down. This motion is conducive to the mechanism that allows for the light to be adjustable. The sliding head of the lamp is clipped onto the stem and can be easily adjusted up and down with a very easy motion.

Available in six finishes: green, terracotta, mustard, black, off-white, and moss grey. The Marset Funiculi desk lamp can rotate 360 degrees around the stem of the lamp. This rotation allows the light to be directed and adjusted with ease. This lamp is perfect for an office, workspace or bedside table as it has a large amount of indirect light as well as directional light for reading and working.



## PRODUCT SPECIFICATION

**Light Source:** 1 x Max 5W LED E14 (excluded)

**IP Code:** 20

**Dimming:** In line on/off switch included on cable.

**Dimensions:** Base: Ø19.7cm  
Height: 50.3cm  
Shade: Ø15.5cm  
Cable Length: 200cm

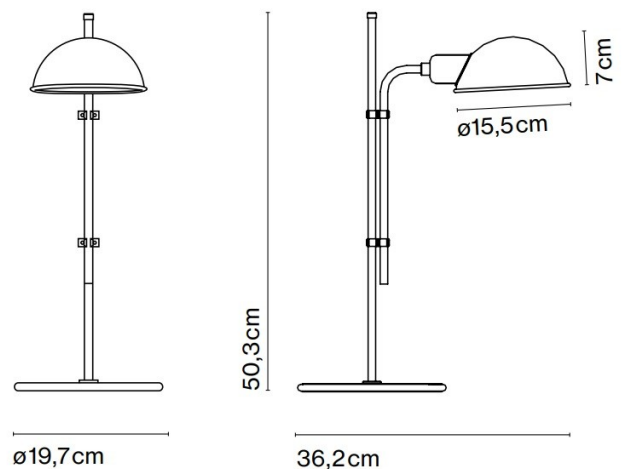



**For all sales and technical enquiries, please contact:**

+44 (0)114 263 4266

[info@davidvillagelighting.co.uk](mailto:info@davidvillagelighting.co.uk)

[www.davidvillagelighting.co.uk](http://www.davidvillagelighting.co.uk)