

VIBIA

Vibia Flamingo 1560 LED Pendant

LA4229

SOURCE: <https://www.davidvillagelighting.co.uk/product/Vibia-Flamingo-1560-LED-Pendant/17041>



PRODUCT DESCRIPTION

Designer: Antoni Arola

Vibia Flamingo 1560 LED Pendant

Inspired by the elegant poise of the flamingo, designer Antoni Arola interprets the bird with a range of pendant lights known as the [Vibia Flamingo collection](#). The Flamingo 1560 pendant light features three integrated LED light sources with two pointing downwards for a spotlight and an ambient glow and the third pointing upwards to reflect off the shades.

The Flamingo 1560 pendant lamp features four round lampshades that are conical in nature to create a warm and welcoming atmosphere by spreading and reflecting the light. The light sources are held by a slim metal stem, creating a beautiful and contemporary aesthetic. Available in multiple finishes, use this pendant as a main light or in multiple and hung over tables in homes, offices, hospitality venues and more for effective and modern lighting.

The Flamingo 1560 pendant is also in various colour temperature, cable length and dimming options. Please [contact us](#) for more information and pricing.

PRODUCT SPECIFICATION

- Light Source:** 3 x 5.6W, 2700K, 2083 Lumens
- IP Code:** 20
- Dimming:** Dimmable via 1-10V or PUSH dimming systems. Please consult your electrician, additional wiring may be required on site.
- Dimensions:** Shade: Ø90cm
Height: 155cm
Ceiling Canopy: Ø16cm
Maximum Drop: 350cm

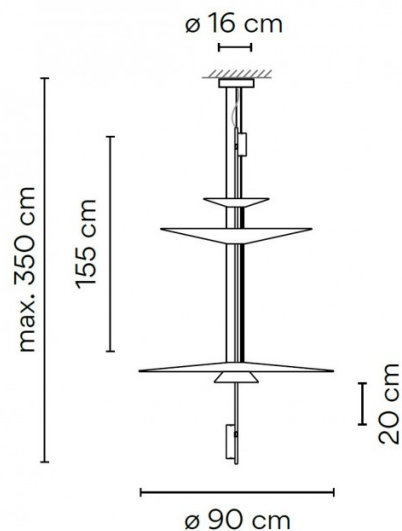



For all sales and technical enquiries, please contact:

+44 (0)114 263 4266

info@davidvillagelighting.co.uk

www.davidvillagelighting.co.uk