

VIBIA

Vibia Flamingo 1530 LED Pendant

LA4226

SOURCE: <https://www.davidvillagelighting.co.uk/product/Vibia-Flamingo-1530-LED-Pendant/17038>



PRODUCT DESCRIPTION

Designer: Antoni Arola

Vibia Flamingo 1530 LED Pendant Light

Designed by Antoni Arola, the Flamingo 1530 is an iconic pendant light, inspired by the delicate stance of the flamingo bird. The pendant lamp features three lampshades made of acrylic that both diffuse and reflect the light sources. The LEDs sit in the metal structure, with two of them shining downwards and one of them reflecting upwards to create both direct and indirect illumination.

The metal stem is available in various finishes, so you can find the right look for your space. The Flamingo 1530 pendant lamp can be used in a wide variety of settings, useful as both a main light in smaller spaces or as accent lighting in larger spaces.

The Flamingo 1530 pendant is also available with customisable dimming, colour temperature and cable length options. Please [contact us](#) for more info and prices.

PRODUCT SPECIFICATION

Light Source:	3 x 5.6W, 2700K, 2083 Lumens
IP Code:	20
Dimming:	Dimmable via 1-10V or PUSH dimming systems. Please consult your electrician, additional wiring may be required on site.
Dimensions:	Shade: Ø90cm Height: 100cm Ceiling Canopy: Ø16cm Maximum Drop: 350cm

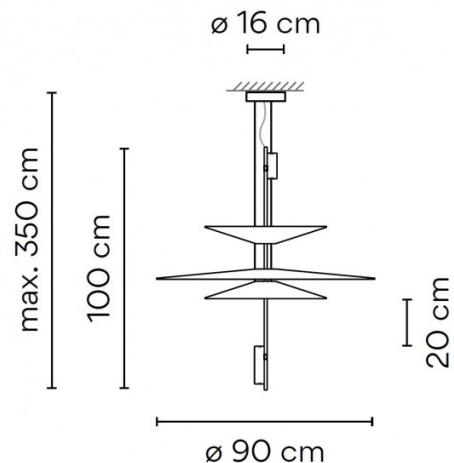



For all sales and technical enquiries, please contact:

+44 (0)114 263 4266

info@davidvillagelighting.co.uk

www.davidvillagelighting.co.uk