

FOSCARINI

Foscarini Havana Outdoor Floor Lamp

LA3558/U

SOURCE: <https://www.davidvillagelighting.co.uk/product/Foscarini-Havana-Outdoor-Floor-Lamp/16079>



PRODUCT DESCRIPTION

Designer: Jozeph Forakis

Foscarini Havana Outdoor Floor Lamp

A part of the iconic [Foscarini Havana collection](#), the Havana outdoor floor lamp brings all the style and chicness of the Havana range to the outdoors. Made from 4 parts held together by metal rings, the floor lamp takes its silhouette from the shape of a cigar. The subtle gaps in the parts let the light escape, providing much-needed illumination and the white diffusers conceal the light source to produce a warming glow.

Perfect for many exteriors, the Havana outdoor floor light comes in 2 sizes, low or high, and with the choice of 3 bases. The **cylinder and picket bases** allow you to bury the base to have a stable lamp that is a beautiful permanent fixture. The **repositional base** is a square base that allows you to move the lamp around, being a perfect solution for lighting in any outdoor area. Use in patios, terraces, gardens or even to light your driveway to have a contemporary and classic design light up the space.

PRODUCT SPECIFICATION

Light Source: 1 x Max 46W E27 (excluded)

IP Code: 44-65

Dimming: Non-Dimmable.

Dimensions: **Low Height:** 144cm
High Height: 173.5cm

Picket Base:

Ø13cm
Depth: 42cm

Cylinder Base:

Ø13cm
Depth: 19cm

Repositional Base:

28cm x 28cm
Depth: 1cm

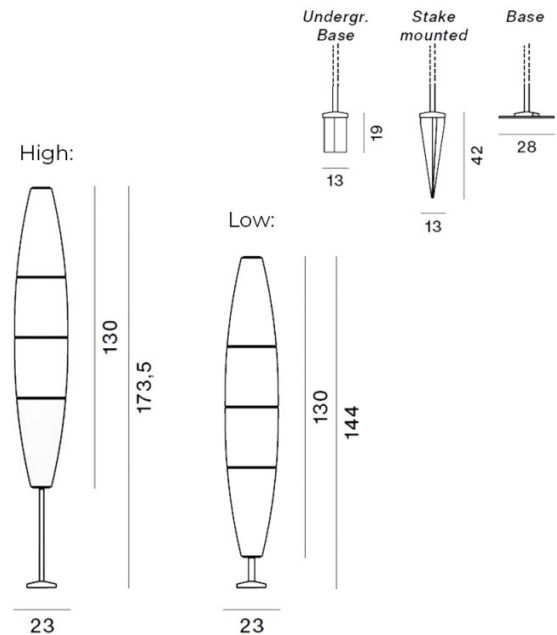



For all sales and technical enquiries, please contact:

+44 (0)114 263 4266

info@davidvillagelighting.co.uk

www.davidvillagelighting.co.uk