



LA6337/M1

Santa & Cole Basica M1 Table Lamp

SOURCE: <https://www.davidvillagelighting.co.uk/product/Santa-Cole-Basica-M1-Table-Lamp/15141>



PRODUCT DESCRIPTION

Designer: Santiago Roqueta

Santa & Cole Basica M1 Table Lamp

Oposing the current trends in the 1980s, where metallic tubular designs with halogen lamps were prevailing, the Basica table lamp was Santa & Cole's alternative. The lamp was designed by Santiago Roqueta in collaboration with the brand's design team, and has since become a bestseller of the brand and laid the foundation for new trends in the European market. Even now, 30 something years later the lamp is as relevant as ever.

The Basica has a wooden column that is balanced by a heavy metallic base in a nickel or bronze finish. The Basica M1 shade comes in eight different fabric finishes, white linen, mustard ribbon, green ribbon, black ribbon, stitched beige parchment, red-amber ribbon, terracotta ribbon and natural ribbon. Although not needed for the lamp to maintain its balance, you can also choose to have an optional disc which has a wider base in a matching metal finish.

The collection also includes the [Basica M2](#), which is paired with the M2 shade (40 x 20), available only in a stitched beige parchment finish, and the smaller version of the Basica M1, the [Basica Minima](#).

PRODUCT SPECIFICATION

Light Source: 1 x Max 11W E27 LED (included)

IP Code: 20

Dimming: In-line on/off switch on the cable.

Dimensions: Shade: Ø25cm
Shade Height: 20cm
Total Height: 52cm
Base Without Disc: Ø5cm
Base With Disk: Ø8.5cm
Cable Length: 225cm

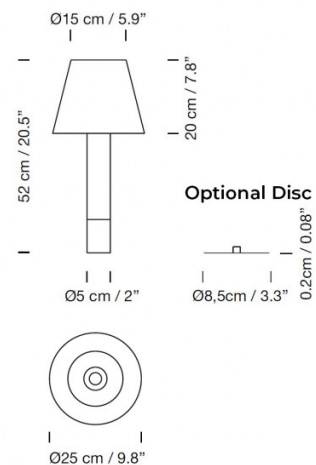



For all sales and technical enquiries, please contact:

+44 (0)114 263 4266

info@davidvillagelighting.co.uk

www.davidvillagelighting.co.uk