

VIBIA

Vibia Puck Wall / Ceiling Light

LA7302

SOURCE: <https://www.davidvillagelighting.co.uk/product/Vibia-Puck-Wall-Ceiling-Light/14505>

PRODUCT DESCRIPTION

Designer: Jordi Vilardell

Vibia Puck Wall / Ceiling Light

Designed by Jordi Vilardell, the Vibia Puck Wall/Ceiling Light is a sleek lighting solution, consisting of a circular glass diffuser that produces diffused glare-free light. The use of top-quality opal triplex glass and injection-moulded aluminium gives the product a perfect finish, resulting in an elegant contemporary wall or ceiling light. Utilising a white finish the Puck Wall/Ceiling Light can adapt to almost any interior and match a range of personal styles.

With a diameter of 24.4cm, this lighting solution can be displayed individually for a more subtle lighting option or displayed in multiples for larger spaces for a more dramatic effect. Display the Vibia Puck LED Wall/Ceiling Light in hallways, kitchens, or living areas in residential spaces. Similarly, it can make a beautiful impact in commercial environments such as shops, salons, restaurants, bars or hotels.

PRODUCT SPECIFICATION

Light Source: 2 x Max 4.2W G9 LED (excluded)

IP Code: 20

Dimming: Non-Dimmable.

Dimensions: Ø24.4cm
Depth: 6.6cm

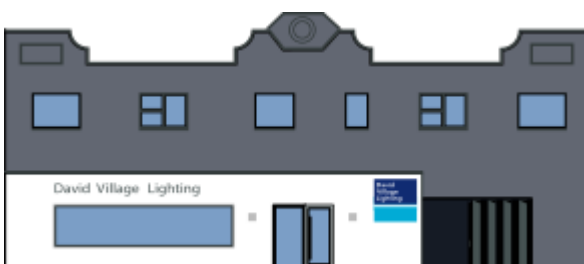
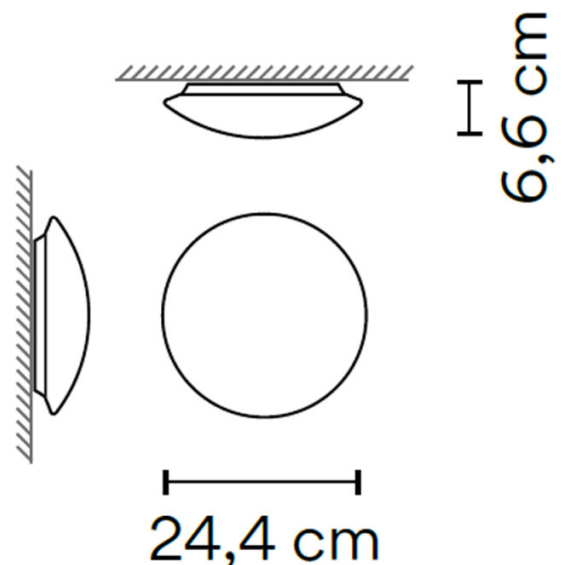

For all sales and technical enquiries, please contact:

+44 (0)114 263 4266

info@davidvillagelighting.co.uk

www.davidvillagelighting.co.uk