

marset

Marset Lab 2 LED Wall Light

LA98/2W

SOURCE: <https://www.davidvillagelighting.co.uk/product/Marset-Lab-2-LED-Wall-Light/13782>



PRODUCT DESCRIPTION

Designer: Francesc Rife

Marset Lab 2 LED Wall Light

The Marset Lab 2 is an outdoor wall lamp that incorporates LED technology. The Marset Lab 2 Outdoor LED Wall Light can easily blend in to or stand out from its surroundings, making it an extremely versatile fixture ideal for a variety of applications.

PRODUCT SPECIFICATION

Light Source: 9W, 3000K, 630 Lumens

IP Code: 65

Dimming: Non-dimmable.

Dimensions: Width: 12.6cm
Length: 12.6cm
Depth: 8cm
Lid: 12.6 x 12.6cm

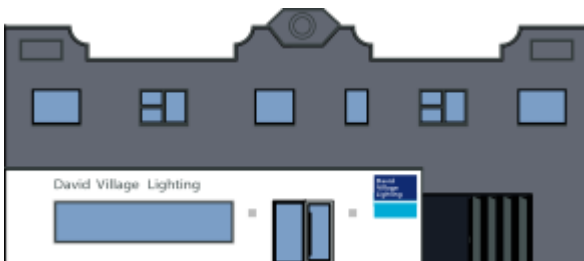
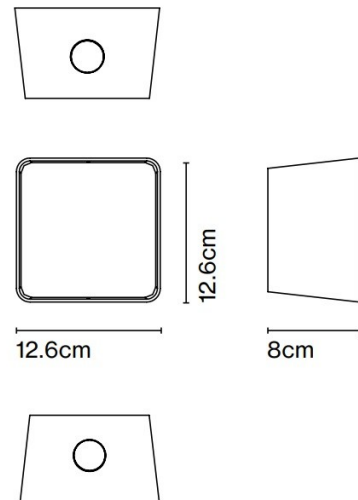

For all sales and technical enquiries, please contact:

+44 (0)114 263 4266

info@davidvillagelighting.co.uk

www.davidvillagelighting.co.uk