



Moooi Construction Floor Lamp

LA6566

SOURCE: <https://www.davidvillagelighting.co.uk/product/Moooi-Construction-Floor-Lamp/13436>



PRODUCT DESCRIPTION

Designer: Joost van Bleiswijk

Construction Lamp by Moooi

Joost van Bleiswijk designed the Construction Lamp Collection by merging his curiosity and expert skills with a final touch of his passion for vintage toys. With a series of tools and screws in his workshop, van Bleiswijk constructed a whole new idea! The floor lamps are available in two sizes (Medium and Large) and two colour options: matt black with brass screws or matt white / wood with brass screws.

The beauty of this design lies in the details, a series of joints that remind us of Victorian cast iron elements and they all come together to form a shape of an electrical pole, in its traditional design. A lamp with a hint of industrial influences and a playful touch. In the same way that old toys or scaffolding were manual put together, the Construction lamps are assembled by hand.

PRODUCT SPECIFICATION

Light Source: **Medium** - 2 x Max 75W E27 (excluded)

Large - 4 x Max 75W E27 (excluded)

IP Code: 20

Dimming: In line dimmer included on cable.

Dimensions: **Medium** - Shade: Ø67cm, Height: 139cm

Large - Shade: Ø90cm, Height: 185cm

Cable Length: 300cm

67 cm | 26.4"

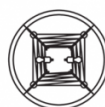

90 cm | 35.4"



139 cm | 54.7"

Medium

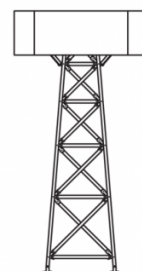

185 cm | 72.8"

Large

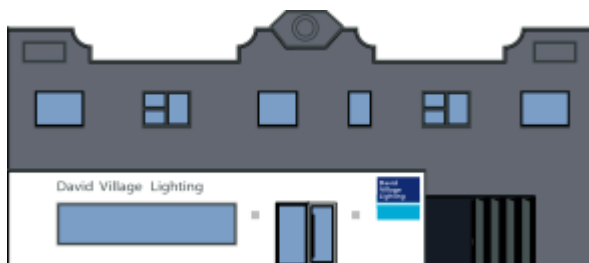

For all sales and technical enquiries, please contact:

+44 (0)114 263 4266

info@davidvillagelighting.co.uk

www.davidvillagelighting.co.uk