

Tom Raffield

Tom Raffield Mooring Table Lamp

LA11172

SOURCE: <https://www.davidvillagelighting.co.uk/product/Tom-Raffield-Mooring-Table-Lamp/10002200>

PRODUCT DESCRIPTION

Designer: Tom Raffield

Tom Raffield Mooring Table Lamp

The Mooring Table Lamp is part of the Mooring collection by Tom Raffield. Crafted from oak, it is available in a natural oak finish or the "Noctis" ebonised oak edition. The natural oak finish has a light tone that blends seamlessly into a wide range of decors. When illuminated, light bathes the wood in a warm glow that highlights its natural beauty. The Noctis lamp has an ebonised oak finish that is a much darker, richer finish that creates a striking contrast when displayed alongside lighter wooden furniture. When illuminated the light creates rich hues that accentuate the luxurious finish. A single bulb is suspended from a textile cord, an uncluttered detail that adds to the lamp's refreshingly simplistic profile.

Tom Raffield is a pioneer in steam-bending wood, a technique synonymous with his brand. This method has been used when creating the Mooring Table Lamp to form the natural-looking curve at the top of the frame. Steam-bending is a low-wastage and low-energy process that allows Tom Raffield's studio to be sustainable, making the smallest ecological footprint possible. Created from sustainably sourced wood and crafted to last a lifetime, the Mooring Table Lamp is an innovative, contemporary design suited for domestic and commercial interiors.



PRODUCT SPECIFICATION

Light Source: 1 x Max 25W E27 LED (Excluded)

IP Code: 20

Dimming: In-line on/off switch included on cable.

Dimensions: Height: 52cm
Width: 18.5cm
Length: 17cm
Cable Length (from plug to bulb holder): 228cm

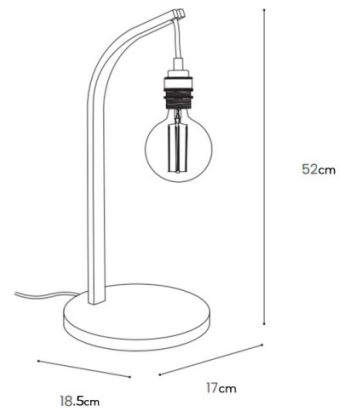



For all sales and technical enquiries, please contact:

+44 (0)114 263 4266

info@davidvillagelighting.co.uk

www.davidvillagelighting.co.uk