



LA11117/SSP

Bocci 100s/sp LED Wall / Ceiling Light

SOURCE: <https://www.davidvillagelighting.co.uk/product/Bocci-100ssp-LED-Wall-Ceiling-Light/10002085>

PRODUCT DESCRIPTION

Designer: Omer Arbel

Bocci 100s/sp LED Wall / Ceiling Light

The Bocci 100s/sp Wall / Ceiling Light is a striking testament to Bocci's unique approach to glass artistry. Multiple glassblowers work in unison, melding glass spheres into a complex, layered structure that is then meticulously cut with a diamond saw to reveal a play of inner and outer surfaces. This process gives each 100s/sp light a one-of-a-kind aesthetic, with LED illumination that enhances the glass's textured, sculptural quality and provides an ambient, nuanced glow.

Mounted on either a white or brass-finish base, the 100s/sp light can be installed on walls or ceilings, adding versatility and elegance to any space. The piece's soft, organic shape, paired with the controlled chaos of the glasswork, makes it a captivating focal point, whether used as a single statement piece or in clusters. This handmade fixture captures the spirit of Bocci's craftsmanship, bringing a sophisticated blend of art and functionality to residential or commercial settings.

Please note that the handcrafted nature of this product means that each piece will be unique and will vary in size and shape.



PRODUCT SPECIFICATION

- Light Source:** 1W, 2700K, 100 Lumens
2500K and 3000K options are available on request.
- IP Code:** 30
- Dimming:** Dimmable via trailing edge mains phase (Please note control must be compatible with electronic low voltage)
- Dimensions: 100s:**
Width/Height: Ø17-21cm (Size will vary)
Depth: Ø17-21cm (Size will vary)
Base Plate Size: Ø5.5cm
- 100sp:**
Width/Height: Ø17-21cm (Size will vary)
Depth: Ø17-21cm (Size will vary)
Base Plate Size: Ø11.5cm

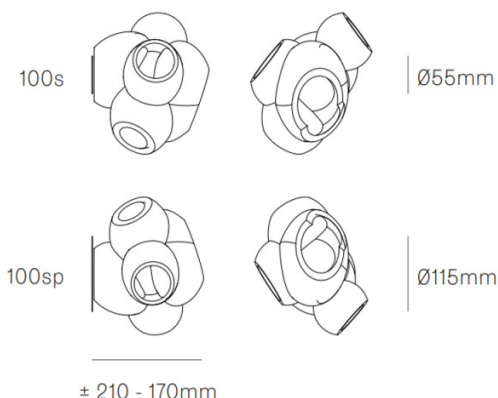



For all sales and technical enquiries, please contact:

+44 (0)114 263 4266

info@davidvillagelighting.co.uk

www.davidvillagelighting.co.uk