

pholc

# Pholc Half Meter Table Lamp

LA10882/T

SOURCE: <https://www.davidvillagelighting.co.uk/product/Pholc-Half-Meter-Table-Lamp/10001353>

## PRODUCT DESCRIPTION

**Designer:** Anne Dorthe Vester & Maria Bruun

### Pholc Half Meter Table Lamp

Pholc Half Meter Table Lamp was created by Danish design pair, Maria Bruun and Anne Dorthe Vester. The Half Meter Table Lamp is inviting and velvety but with a powerful presence. The difference between the natural aluminium frame and the soft cocoon material creates a distinguishable tension. The Half Meter Table Lamp is a design that radiates minimalism and boldness in one.

The Half Meter Table Lamp column-shaped structure is made up of wire which is wrapped by hand in cocoon material whilst the base of the lamp is constructed from unpainted aluminium. The light source is built into the base creating an upward light into the shade. This table lamp can also be doubled as a small floor lamp. The Half Meter Table Lamp is also available as a floor lamp: [One Meter](#).



## PRODUCT SPECIFICATION

**Light Source:** 1x Max 15W, E27 (Excluded)

**IP Code:** 20

**Dimming:** Integrated dimmer on the cable

**Dimensions:** Base diameter: Ø 27.5cm  
 Shade diameter: Ø 32cm  
 Height total: 50cm  
 Base height: 11.6cm  
 Cable: 250cm

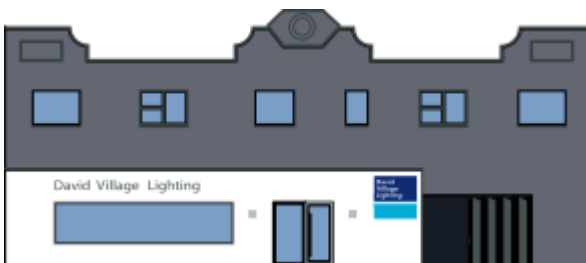
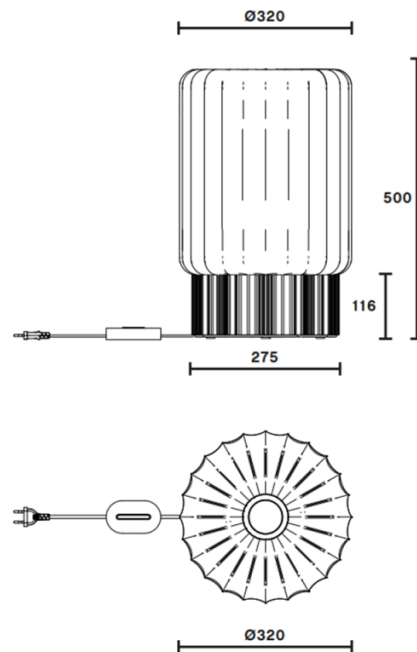

**For all sales and technical enquiries, please contact:**

+44 (0)114 263 4266

[info@davidvillagelighting.co.uk](mailto:info@davidvillagelighting.co.uk)

[www.davidvillagelighting.co.uk](http://www.davidvillagelighting.co.uk)