

mater

Mater Ocean Lounge Chair

LA10802/LOUNGE

SOURCE: <https://www.davidvillagelighting.co.uk/product/Mater-Ocean-Lounge-Chair/10001074>

PRODUCT DESCRIPTION

Designer: Jorgen Ditzel & Nanna Ditzel

Mater Ocean Lounge Chair

Please Note: The Ocean Lounge Chair comes in a pack of 2. The price shown is the price per chair.

The Mater Ocean Lounge Chair is a slightly larger version of the [Mater Ocean Chair](#). The original design was first created in 1955 courtesy of Jorgen and Nanna Ditzel, but Mater later evolved the Ocean collection and manufactured a modern evolution. The evolved Ocean collection utilises plastic waste, combining innovative solutions to prevent pollution of the world's oceans.

Mater's Ocean Lounge Chair in Black, Sand and Burnt Red are crafted from recycled fishing nets and plastic, whilst the Green OC2 utilises discarded Carlsberg beer kegs - resulting in the green finish. Not only is the Mater Ocean Lounge Chair crafted from recycled materials but it can also be fully disassembled, allowing it to be fully recycled at the end of its lifespan. Ocean can be used in both indoor and outdoor settings, making it perfect for sophisticated garden seating or indoor dining seating. It also boasts a curved seat to provide optimal comfort for its user.



PRODUCT SPECIFICATION

Dimensions: Height: 67cm  
Seat Height: 39cm  
Width: 72cm  
Depth: 63cm

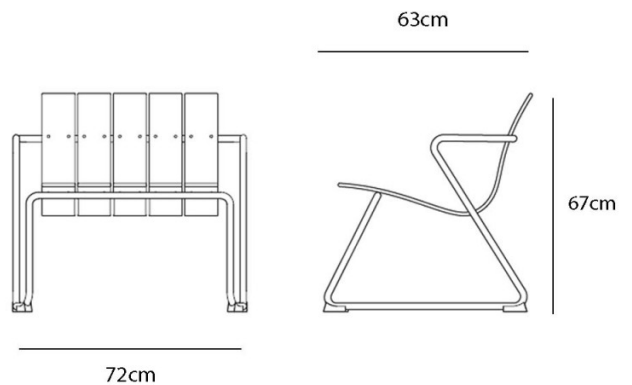



**For all sales and technical enquiries, please contact:**

+44 (0)114 263 4266

[info@davidvillagelighting.co.uk](mailto:info@davidvillagelighting.co.uk)

[www.davidvillagelighting.co.uk](http://www.davidvillagelighting.co.uk)