

mater

Mater Ocean Chair

LA10802

SOURCE: <https://www.davidvillagelighting.co.uk/product/Mater-Ocean-Chair/10001073>

PRODUCT DESCRIPTION

Designer: Jorgen Ditzel & Nanna Ditzel

Mater Ocean Chair

**Please Note: The Ocean Chairs come in a pack of 4. Price shown is the price per chair.**

The Mater Ocean Chair is a perfect combination of functional design and sustainable ethos. Ocean was originally designed in 1955 by Jorgen and Nanna Ditzel, Mater reimaged this collection and optimised the classic design for a modern-day audience. The chair's most prominent feature is the materials used to craft it, the Ocean Chair in Black, Sand and Burnt Red are crafted from recycled fishing nets and plastic, whilst the Green OC2 utilises discarded beer kegs. The green version was born from a collaboration with Carlsberg; hence the colour of the chair.

This chair is characterized by its light structure with repeated curved slats and metal frames, Ocean can be used for both indoor and outdoor use and has been tested for external weather. The Mater Ocean Chair can be stacked in sets of up to six, allowing for easy transportation, and can be disassembled at the end of its lifespan - allowing it to be fully recycled into new production circles. Ocean was the winner of the Wallpaper Design Award in early 2019.

The Mater Ocean Chair is also available as a [Lounge Chair](#).



PRODUCT SPECIFICATION

**Dimensions:** Height: 81cm  
Seat Height: 46cm  
Width: 60cm  
Depth: 56cm

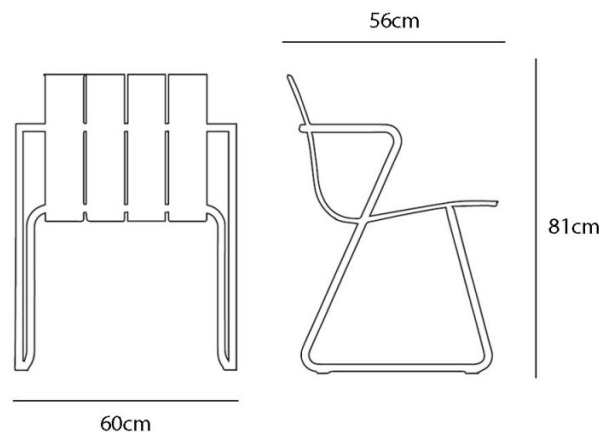



**For all sales and technical enquiries, please contact:**

+44 (0)114 263 4266

[info@davidvillagelighting.co.uk](mailto:info@davidvillagelighting.co.uk)

[www.davidvillagelighting.co.uk](http://www.davidvillagelighting.co.uk)