



# Design For The People Strap Floor Lamp

LA10616/F

SOURCE: <https://www.davidvillagelighting.co.uk/product/Design-For-The-People-Strap-Floor-Lamp/10000617>



## PRODUCT DESCRIPTION

Designer: Bjørn + Balle

### Design For The People Strap Floor Lamp

The Strap floor lamp is the epitome of Scandinavian design, featuring a simple coned lampshade and sleek structure. The shade features a leather strap which adds a touch of modernity to an otherwise classic silhouette. The combination of metal and leather also creates an interesting aesthetic as contrasting materials work together to produce an interactive experience.

The Strap floor light comes with both a black and a brown strap in the purchase, allowing you to choose or even swap between the two depending on the look and style you want. The floor lamp also comes in either a black or white colour finish, with both being a universal colour that can fit into any design scheme. Use as an effective ambient light in lounges, bedrooms and more in any setting.

## PRODUCT SPECIFICATION

**Light Source:** 1 x Max 40W E27 (excluded)

**IP Code:** 20

**Dimming:** Integrated on/off switch on the product.

**Dimensions:** Shade: Ø36cm  
Shade Height: 37cm  
Height: 153.7cm  
Base: Ø30cm  
Cable Length: 180cm

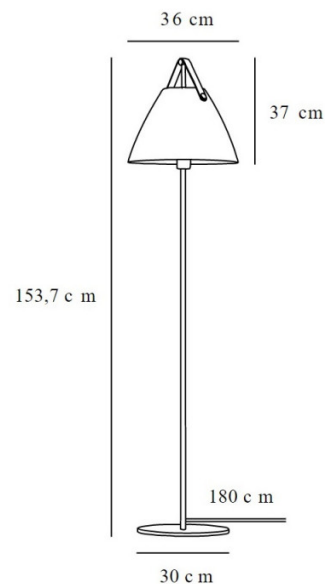

For all sales and technical enquiries, please contact:

+44 (0)114 263 4266

info@davidvillagelighting.co.uk

www.davidvillagelighting.co.uk