



Design For The People Strap Table Lamp

LA10616

SOURCE: <https://www.davidvillagelighting.co.uk/product/Design-For-The-People-Strap-Table-Lamp/10000614>

PRODUCT DESCRIPTION

Designer: Bjørn + Balle

Design For The People Strap Table Lamp

Designed by Bjørn + Balle for Design For The People and the winner of the Red Dot Design Award in 2017, the Strap Table Lamp features a conical lampshade which is supported by a leather strap. This combination of materials and aesthetics produces a modern look and a design which is intrinsically inspired by the Nordic style.

The simple and clean look of the Strap table light makes it perfect for many settings, offering a soft and diffused illumination that can be used for a warm pocket of light in the room. The table lamp is available in either a white or black colour finish and comes with two leather straps in the purchase so you can decide between a brown or black strap to finish the look off in your interior.



PRODUCT SPECIFICATION

- Light Source:** **Black** - 1 x Max 40W E27 (excluded)
Nickel - 1 x Max 25W G9 (excluded)
White - 1 x Max 40W E27 (excluded)
- IP Code:** 20
- Dimming:** Integrated on/off switch on the product.
- Dimensions:** Shade: Ø17cm
Shade Height: 15.5cm
Height: 55cm
Base: Ø17cm
Cable Length: 180cm

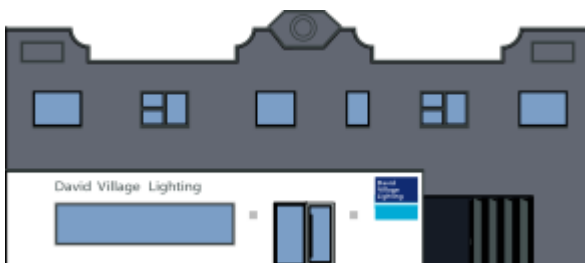
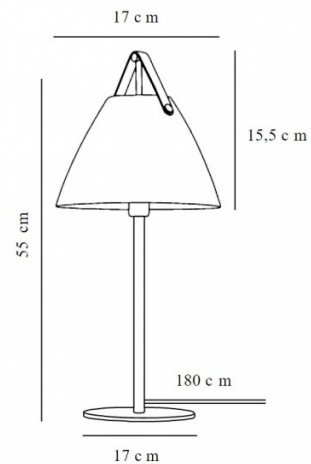

For all sales and technical enquiries, please contact:

+44 (0)114 263 4266

info@davidvillagelighting.co.uk

www.davidvillagelighting.co.uk