

ANGLEPOISE®

Anglepoise Original 1227 Floor Lamp National Trust

LA10582/F

SOURCE: <https://www.davidvillagelighting.co.uk/product/Anglepoise-Original-1227-Floor-Lamp-National-Trust/10000523>

PRODUCT DESCRIPTION

Designer: George Carwardine

Anglepoise Original 1227 Floor Lamp National Trust Edition

The Anglepoise Original 1227 Floor Lamp is a highly adjustable reading lamp that features the classic Anglepoise silhouette and spring mechanisms. This classic-looking lamp has been a well-loved design that has a lifetime guarantee that it will provide light and joy for many many years. This limited edition Original 1227 floor lamp is in collaboration with the National Trust, a charity that was founded in 1895 and has grown to be Europe's largest conservation charity. By purchasing this National Trust limited edition Original 1227 floor lamp, Anglepoise will make a contribution to the charity to help with the conservation, enhancement, and protection of the National Trust sites.

The limited edition buttermilk, sage green and neptune blue finish is brand new and beautifully compliments the brass and chrome detailing. This sage green is also muted and would suit many different kinds of interiors. From placing it in a living space to bring an ambient light to a neglected corner or placing it next to a desk for a more direct task light for reading and working. The National Trust Limited Edition Original 1227 Floor Lamp by Anglepoise is a stunning addition to any home and beautifully showcases the delicate buttermilk, sage green and neptune blue finish.

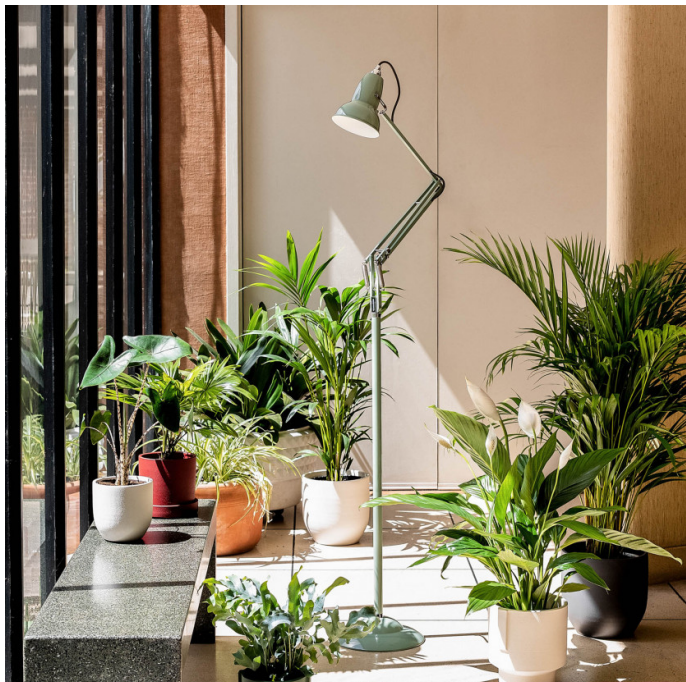

PRODUCT SPECIFICATION

- Light Source:** 1 x max 6W E27 LED (included)
- IP Code:** 20
- Dimming:** In line on/off switch included on cable.
- Dimensions:** 178cm max height
72cm max reach
Ø14cm shade
Ø26cm base

Max Horizontal Reach 72 cm
Max Vertical Reach 178 cm

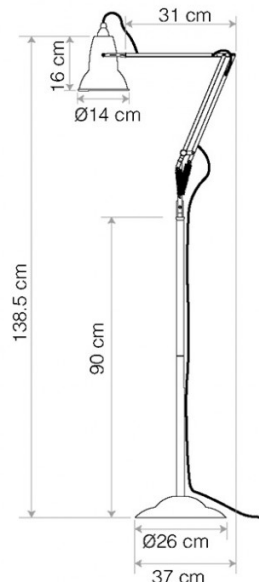



For all sales and technical enquiries, please contact:

+44 (0)114 263 4266

info@davidvillagelighting.co.uk

www.davidvillagelighting.co.uk