



LA10542

&Tradition Caret Portable Table Lamp

SOURCE: <https://www.davidvillagelighting.co.uk/product/Tradition-Caret-Portable-Table-Lamp/10000371>

PRODUCT DESCRIPTION

Designer: Matteo Fogale

&Tradition Caret MF1 Portable Table Lamp

The new **rechargeable** portable lamp Caret MF1 was designed by Matteo Fogale for &Tradition. Caret is a tribute to the traditional banker's lamp, with a modern twist. Its name, Caret, comes from the grapheme used to indicate that something is missing and needs to be added in a sentence or word in typography and proofreading. As such Fogale wants to indicate that the Caret is what's missing from your home; to place on a table or on any shelves. The choice of colour options, Dark Burgundy and Silky Grey allow you to complement any furniture settings. Both are timeless colours, sure to endure trend changes.

Caret can be used in exterior settings (IP44) and its portability and lightweight allow you to easily transfer and use in various spaces. The lamp is dimmable with a **touch dimmer**, and has 4 settings, from 100%, 70%, 40% and 0%. When in use, the Caret can last up to 11 hours on the highest setting and takes 3.5 hours to charge. A **USB magnetic micro cable** is supplied, but the lamp is also compatible with &Tradition's charging tray for multiple lamps.

While the Caret is supplied with 1 **replaceable battery**, you can add a second battery to this product and increase its operating time to 20 hours. The charging time for both lamps is 6 hours. Replacement Batteries and bulbs can be supplied by &Tradition. For more information and pricing, please [contact us](#).



PRODUCT SPECIFICATION

Light Source: 1 x Max 1W G4 LED (included)

IP Code: 44

Dimming: Integrated dimmer on the product.

Dimensions: Width: 15cm
Depth: 10cm
Height: 22cm
Charging Cable: 200cm

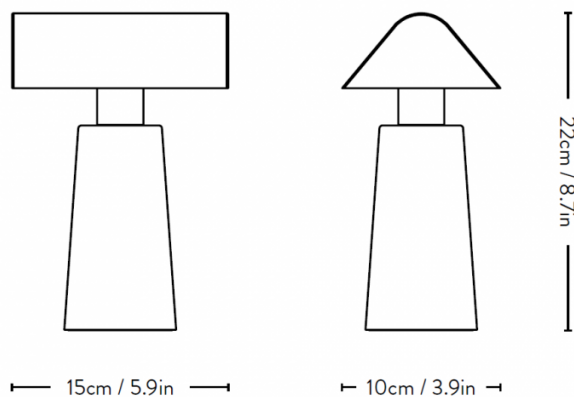

MF1



For all sales and technical enquiries, please contact:

+44 (0)114 263 4266

info@davidvillagelighting.co.uk

www.davidvillagelighting.co.uk