

**CLEARANCE  
OFFERS**

**KDLN Yuma Suspension  
CLEARANCE**

LA5280/CLEARANCE

SOURCE: <https://www.davidvillagelighting.co.uk/product/KDLN-Yuma-Suspension-CLEARANCE/10000338>



**PRODUCT DESCRIPTION**

Designer: David Pompa

**Yuma Suspension Light by KDLN**

**BRAND NEW, OVERSTOCKED, ORIGINAL PACKAGING.  
1 x Available**

The Yuma pendant was inspired by the Yuma desert that stretches between the USA and northern Mexico. The designer of this pendant, David Pompa, brings this desert to life in the KDLN Yuma suspension that uses spun metal to form a uniquely textured and interesting appearance. This choice of material and method of production is the reason for its comparison with the stunning desert environment.

Ideal for above a dining table or countertop, this suspension lamp uses brushed glass and brass to elevate and reflect the surroundings.

**PRODUCT SPECIFICATION**

**Light Source:** 1 x Max 20W E27 (excluded)

**IP Code:** 20

**Dimming:** Dimmable via mains phase dimming.

**Dimensions:** Ø11cm  
Height: 25.5cm  
Ceiling Canopy: Ø12.5cm  
Cable Length: 180cm

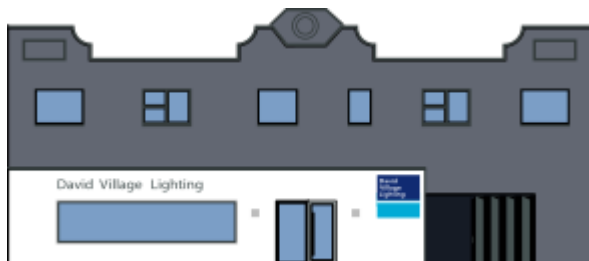
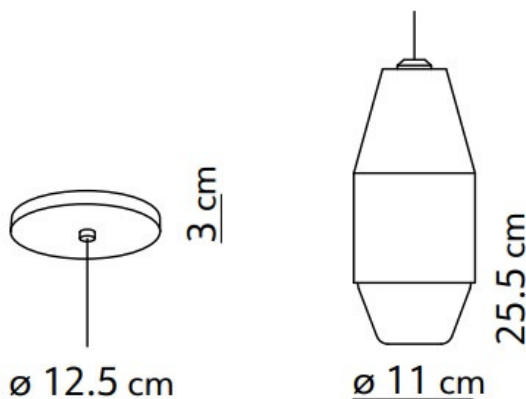

**For all sales and technical enquiries, please contact:**

+44 (0)114 263 4266

info@davidvillagelighting.co.uk

www.davidvillagelighting.co.uk