



# BuzziSpace BuzziPleat LED Pendant

LA10449

SOURCE: <https://www.davidvillagelighting.co.uk/product/BuzziSpace-BuzziPleat-LED-Pendant/10000175>



## PRODUCT DESCRIPTION

### BuzziPleat LED Pendant Light by BuzziSpace

The BuzziPleat pendant is created using traditional fashion techniques such as pleating and smocking as the renowned BuzziFelt material is held by lace, creating dynamic and architectural patterns. BuzziFelt is an amazing material created by the brand which has sound-absorbing abilities, producing a lovely acoustic atmosphere perfect for work spaces.

The BuzziPleat pendant lamp is available in two designs, the Ripple or the Edel, with the ripple having a more traditional curved effect and the Edel having a more angular modern effect. The pendant light also comes with an LED light source with the choice between an LED globe or an LED spot. The globe offers a more overall illumination with a 170° beam angle whereas the spot offers a more concentrated glow with a 38° beam angle.

The BuzziPleat pendant light is useful for absorbing mid and high tones and so is wonderful in large offices in multiple or in meeting rooms to create a happy and calming work space. Available in various fabrics and colours, please contact our [Trade Team](#) to discuss options and prices.

## PRODUCT SPECIFICATION

**Light Source:** 19W, 3000K, 1500 Lumens

**IP Code:** 20

**Dimming:** 20

**Dimming:** Dimmable via 1-10v dimming systems. Please consult your electrician, additional wiring may be required on site.

**Dimensions: Ripple Medium**

Ø100cm

Height: 13cm

**Ripple Large**

Ø150cm

Height: 19.5cm

**Edel Medium**

Ø100cm

Height: 9cm

**Edel Large**

Ø150cm

Height: 13.5cm

Globe LED Source: Ø15cm

Spot LED Source: Ø10.2cm

Ceiling Canopy: 28cm x 14cm

Cable Length: 200cm or 500cm

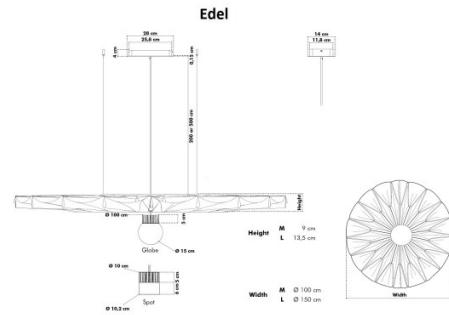
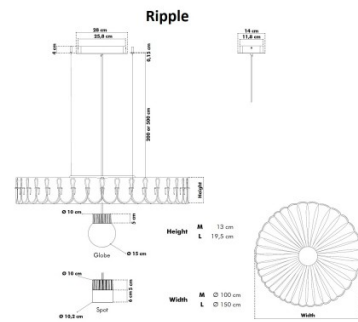

**For all sales and technical enquiries, please contact:**

+44 (0)114 263 4266

[info@davidvillagelighting.co.uk](mailto:info@davidvillagelighting.co.uk)

[www.davidvillagelighting.co.uk](http://www.davidvillagelighting.co.uk)